

Intel® Remote Management Module 3

Technical Product Specification

Intel order number E63789-002

Revision 1.0

March, 2009

Enterprise Platforms and Services Division - Marketing

Revision History

Date	Revision Number	Modifications
March 2009	1.0	Initial Release.

Disclaimers

Information in this document is provided in connection with Intel® products. No license, express or implied, by estoppel or otherwise, to any intellectual property rights is granted by this document. Except as provided in Intel's Terms and Conditions of Sale for such products, Intel assumes no liability whatsoever, and Intel disclaims any express or implied warranty, relating to sale and/or use of Intel products including liability or warranties relating to fitness for a particular purpose, merchantability, or infringement of any patent, copyright or other intellectual property right. Intel products are not intended for use in medical, life saving, or life sustaining applications. Intel may make changes to specifications and product descriptions at any time, without notice.

Designers must not rely on the absence or characteristics of any features or instructions marked "reserved" or "undefined." Intel reserves these for future definition and shall have no responsibility whatsoever for conflicts or incompatibilities arising from future changes to them.

The Intel® Remote Management Module 3 may contain design defects or errors known as errata which may cause the product to deviate from published specifications. Current characterized errata are available on request.

Intel, Pentium, Itanium, and Xeon are trademarks or registered trademarks of Intel Corporation.

*Other brands and names may be claimed as the property of others.

Copyright © Intel Corporation 2009. All rights reserved.

Table of Contents

1. Introduction	1
2. Product Overview.....	2
2.1 Virtual Presence.....	2
2.2 Firmware Feature Set.....	2
2.3 Web Front-end.....	2
2.4 Virtual Media.....	3
2.5 Remote Console.....	4
2.6 Hardware Feature Set.....	4
2.6.1 Functionality.....	4
2.7 Physical Dimensions.....	5
3. Board Architecture.....	8
3.1 USB 2.0 (high-speed) Interface.....	8
3.2 RMI Interface.....	9
3.3 64-MB SDRAM System Memory.....	9
3.4 8-MB Flash.....	9
4. Electrical Specifications.....	10
4.1 3.3 V Auxiliary Operation.....	10
4.2 DC Specifications.....	10
4.2.1 Supported Video Resolutions and Refresh Rates.....	10
4.3 System Reset Control.....	12
5. Network Connections and Authentication.....	13
5.1 Network Connectivity.....	13
5.1.1 Supported Traffic.....	13
Glossary.....	14

List of Tables

Table 1. RMM3 Connector Pin-out	5
Table 2. Supported Video Resolutions and Refresh Rates	10

1. Introduction

This Technical Product Specification (TPS) provides details about the architecture and feature set of the Intel® Remote Management Module 3 (Intel® RMM3). This document does not replace the Intel® RMM3 User's Guide, but provides enhanced information to assist with understanding and learning more about specific features of the board.

2. Product Overview

The Intel® RMM3 is a 1.23-inch x 2.30-inch printed circuit board. When installed onto the Intel® RMM connector on Intel® server boards, it provides an increased level of manageability over basic server management available to the server board.

Designed to work with the Integrated Baseboard Management Controller (BMC), this small form-factor mezzanine card enables graphical server control from anywhere, at anytime.

2.1 Virtual Presence

The Intel® RMM3 provides Virtual Presence (Remote Console) at the host server. This presence includes keyboard / video / mouse (KVM) redirection over Transmission Control Protocol/Internet Protocol (TCP/IP) using an Ethernet network port dedicated for remote management.

The keyboard, video, and mouse of the remote server are available to the administrator from any network location, regardless of the state of the server (OS loading, running, or not responding (blue screen), Pre-OS BIOS boot and setup, etc). The dedicated Ethernet controller supports Out-Of-Band (OOB) access. In other words, it runs separately from the OS and the BIOS. This separation allows the Intel® RMM3 to operate continuously, thus supporting 24 X 7 management of the system. The management traffic does not share network bandwidth with the host system software.

2.2 Firmware Feature Set

- Intel® RMM3 Virtual Presence over remote console: Keyboard/Video/Mouse (KVM) redirection over TCP/IP
- Intel® RMM3 web server supporting HTTPS or HTTP
- Automatically senses video resolution for best possible screen display
- Intel® RMM3 Virtual Media: USB remote storage redirection over TCP/IP, supports one floppy drive or USB flash drive, and one CD/DVD drive at a time
- Intel® RMM3 Virtual Presence over Web Front-end: Power and Reset Control over TCP/IP
- Interaction with the Integrated BMC for support of Intelligent Platform Management Interface (IPMI) 2.0
- Support for a dedicated 10/100 Out-Of-Band (OOB) Management LAN channel
- Local Configuration Utilities for Microsoft Windows* and Linux
- Highest security standards using up to 256-bit SSLv3, Certificate Management, Event Logging, and State-of-the-Art authentication methods

2.3 Web Front-end

The Intel® RMM3 module features an embedded operating system and application offering a variety of standard interfaces. These interfaces are accessed using the TCP/IP protocol family, and therefore, they can be accessed using the built-in Ethernet adapter.

The Intel® RMM3 Web Front-end is a Graphical User Interface (GUI). It offers convenient and secure access to

- Open the Remote Console
- Virtual Media
- System Health
- User Management
- KVM Settings
- RMM3/BMC network settings
- System information

Using a standard web browser on the administrator's client computer, the Intel® RMM3 Web GUI provides Virtual Presence to the server. It offers the user the ability to:

- Obtain detailed system information
- Perform virtual media transfers
- Control power and reset the server

In addition, the Intel® RMM3 allows the user to open a Remote console, see the screen of the target system and work with all applications as if he/she was seated at the system.

All network communication with the Intel® RMM3 is secured using industry-standard authentication, encryption, and access control mechanisms. Access to the Intel® RMM3 Web Console is controlled by a user-based security system.

2.4 Virtual Media

The Intel® RMM3 provides Virtual Media, which is USB remote storage redirection over TCP/IP, using the dedicated LAN interface. Administrators use Intel® RMM3 Virtual Media to:

- Upload a floppy image to the Intel® RMM3, maximum size of 1.44 MB.
- Mount a CD-ROM / DVD-ROM ISO image from the client computer or from a network share.
- Redirect Floppy, CD-ROM / DVD-ROM drives or USB flash drives that are physically local to the administrator's client computer, to appear as a USB mass storage device on the target server.

Once mounted, the media that is remote to the server appears local to the server. This allows administrators to install software or drivers on the server, or boot the server from the remote media.

Intel® RMM3 - Virtual Media can be used to complete the following actions:

- Install a new operating system on a target server
- Perform an operating system upgrade on a target server
- Repair damaged operating system installs

- Transfer files to and from the target server to a remote location

The Intel® RMM3 Virtual Media offers to redirect two drives at a time, which makes it even more comfortable to perform remote OS installations and allows access to use additional driver disks during OS installation. One CD/DVD device, and one floppy device or USB flash drive are supported simultaneously.

It is not advisable to update the Integrated BMC firmware or RMM3 firmware via the RMM3 interface.

2.5 Remote Console

The Remote Console is the redirected screen, keyboard, and mouse of the remote host system where the Intel® RMM3 module is installed. To use the Remote Console window of your managed host system, the browser must include a Java Runtime Environment plug-in. If the browser has no Java support, such as with a small handheld device, the user can maintain the remote host system using the administration forms displayed by the browser. Refer to the Intel® RMM3 User's Guide for specific Java version information.

The Remote Console window is a Java applet that establishes its own TCP connection to the Intel® RMM3 module.

Starting the Remote Console opens a new window to display the screen content of the host system. The Remote Console acts as if the administrator was sitting directly in front of the screen of his/her remote system. This means the keyboard and mouse can be used in the usual way.

2.6 Hardware Feature Set

2.6.1 Functionality

Intel® RMM3 utilizes the on-board ServerEngines* Pilot II Baseboard Management Controller, which is an ARM9 controller with the following features:

- 250 MHz 32-bit ARM9 Processor
- Memory Management Unit (MMU)
- Two 10/100 Ethernet Controllers with NC-SI
- USB 2.0 for Keyboard, Mouse, and Storage devices
- USB 1.1 interface for legacy PS/2 to USB bridging
- Hardware Video Compression for text and graphics
- Hardware encryption
- 2D Graphics Acceleration
- DDR2 graphics memory interface
- Up to 1600x1200 pixel resolution
- PCI Express* x1 support

The Intel® RMM3 connects to the Intel® RMM connector on the Intel® server board via the iPN D16503-004, Amphenol G845B034211, or equivalent connector on the server board.

Table 1. RMM3 Connector Pin-out

Pin	Name	Pin	Name
1	3V3_AUX	2	SMI_MDIO
3	3V3_AUX	4	SMI_MDC
5	GND	6	RMII_RXD1
7	GND	8	RMII_RXD0
9	GND	10	RMII_RX_DV
11	GND	12	RMII_REF_CLK
13	GND	14	RMII_RX_ER
15	GND	16	RMII_TX_EN
17	GND	18	KEY (pin removed)
19	GND	20	RMII_TXD0
21	GND	22	RMII_TXD1
23	3V3_AUX	24	SPI_CS_N
25	3V3_AUX	26	NC (spare)
27	3V3_AUX	28	SPI_DO
29	GND	30	SPI_CLK
31	GND	32	SPI_DI
33	GND	34	RMM3_Present_N

2.7 Physical Dimensions

The Intel® RMM3 is a 1.23" x 2.30" x 0.062" thick printed circuit board that mounts to the system chassis via a mounting bracket. On Intel rack-mounted systems, space is provided to mount the Intel® RMM3 directly to the chassis. Third-party rack-mount chassis and pedestal chassis use an available PCI bracket space to mount the Intel® RMM3.

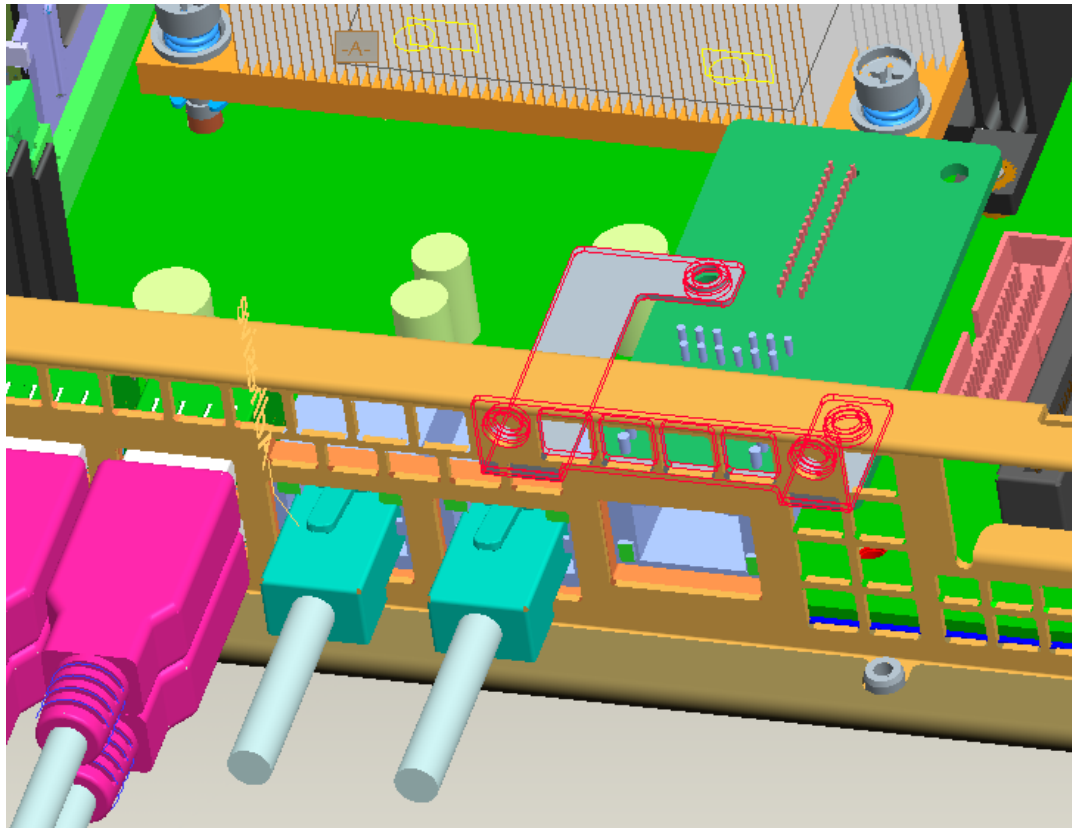
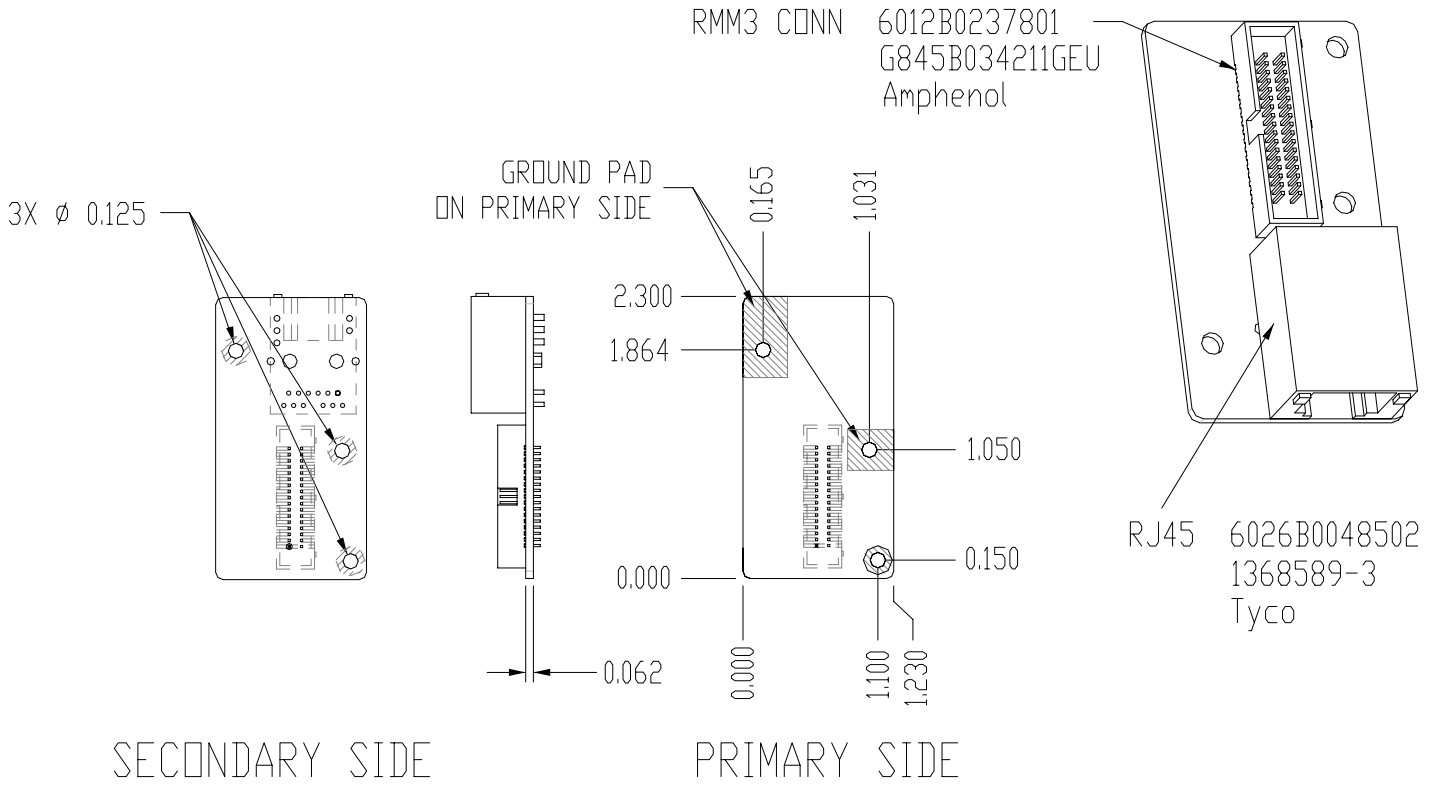

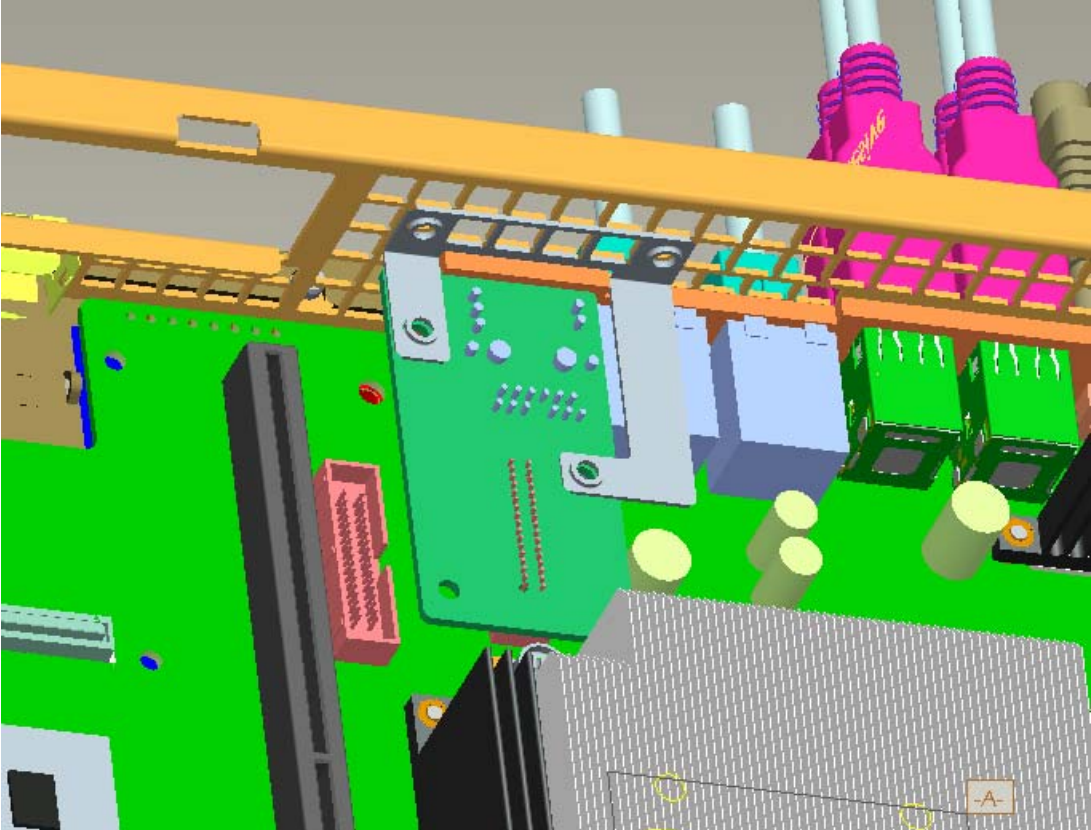

3. Board Architecture

The Intel® RMM3 interfaces via the 34-pin header to the Integrated Baseboard Management Controller (BMC) at the interfaces shown in the following block diagram.

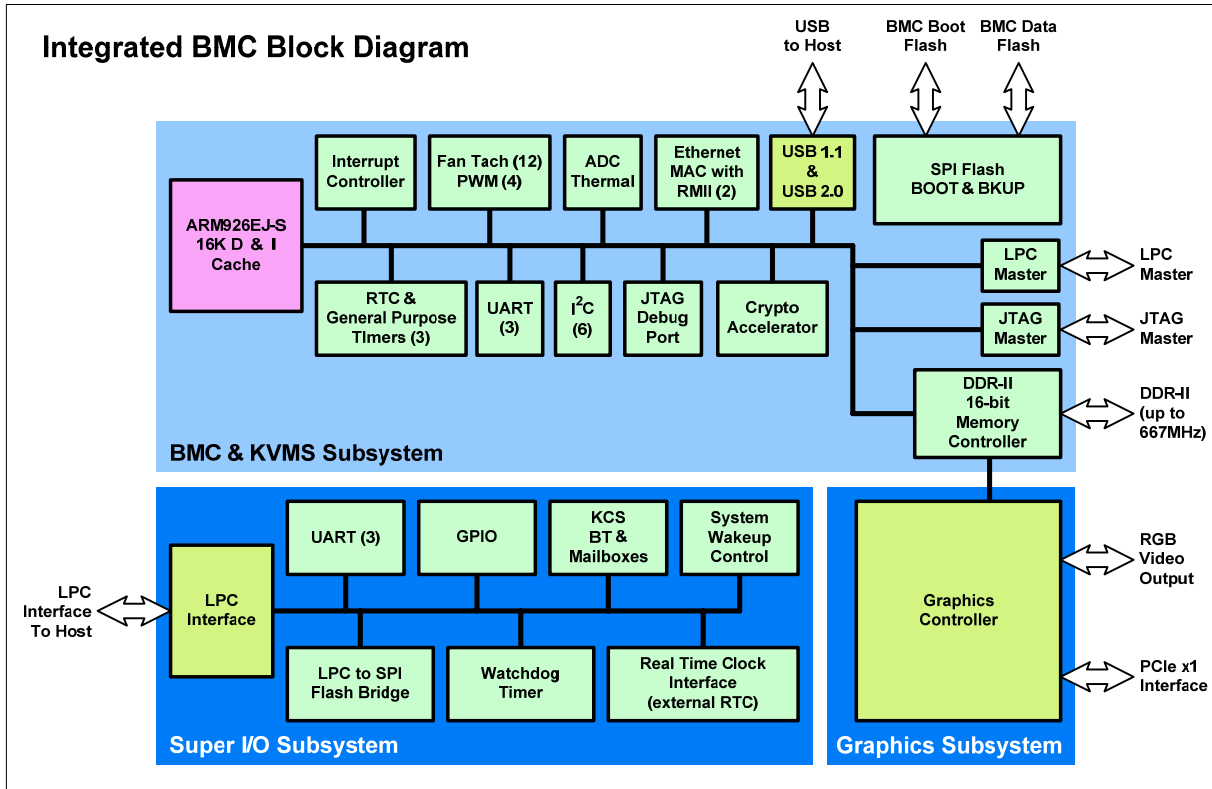

Figure 1: Integrated BMC/Intel® RMM3 block diagram

3.1 USB 2.0 (high-speed) Interface

A USB 2.0 (high-speed) interface supports the following:

- Virtual keyboard
- Virtual mouse
- Intel® RMM3 - Virtual Media

3.2 RMI Interface

The Reduced Media Independent Interface (RMII) is a standard for communication between an Ethernet MAC (Media Access Controller) device and an Ethernet PHY (Physical layer interface) device. The Intel® RMM3 utilizes 8 pins for data and control.

3.3 64-MB SDRAM System Memory

The ServerEngines* Pilot II Baseboard Management Controller uses a 64-MB SDRAM chip. This chip supports running the embedded Linux operating system and all other embedded Intel® RMM3 firmware.

3.4 8-MB Flash

The embedded firmware for the advanced features is stored in an 8-MB flash chip. This is in addition to the 8 MB flash attached to the local bus of the ServerEngines* Pilot II Baseboard Management Controller.

4. Electrical Specifications

4.1 3.3 V Auxiliary Operation

The server board generates the 3.3 V auxiliary supply from the system's 5 V standby power rail when the system is off. Certain other devices on the server board also operate on 5V standby power to provide complete management functionality. When system power is on, the server board generates this power from the 3.3 V system power rail.

The Intel® RMM3 can only be attached and removed when the AC power is disconnected from the server.

4.2 DC Specifications

All pins on the Intel® RMM are 3.3-V tolerant.

4.2.1 Supported Video Resolutions and Refresh Rates

The Intel® RMM3 video redirection features support for the host product according to the standard rates and resolutions supported by the server board video controller.

The following table displays the standard video rates and resolutions supported by the Matrox G200-compatible core within the server board integrated video and management controller.

Table 2. Supported Video Resolutions and Refresh Rates

Width	Height	Vertical Rate	Bits/Pixel	Horizontal Frequency (kHz)	Pixel Frequency (mHz)
640 x 480					
640	480	60	8	31.5	25.175
640	480	60	16	31.5	25.175
640	480	60	32	31.5	25.175
640	480	72	8	37.9	31.500
640	480	72	16	37.9	31.500
640	480	72	32	37.9	31.500
640	480	75	8	37.5	31.500
640	480	75	16	37.5	31.500
640	480	75	32	37.5	31.500
640	480	85	8	43.3	36.000
640	480	85	16	43.3	36.000
640	480	85	32	43.3	36.000
800 x 600					
800	600	60	8	37.9	40.000
800	600	60	16	37.9	40.000

Width	Height	Vertical Rate	Bits/Pixel	Horizontal Frequency (kHz)	Pixel Frequency (mHz)
800	600	60	32	37.9	40.000
800	600	72	8	48.1	50.000
800	600	72	16	48.1	50.000
800	600	72	32	48.1	50.000
800	600	75	8	46.9	49.500
800	600	75	16	46.9	49.500
800	600	75	32	46.9	49.500
800	600	85	8	53.7	56.250
800	600	85	16	53.7	56.250
800	600	85	32	53.7	56.250

1024 x 768

1024	768	60	8	48.4	65.000
1024	768	60	16	48.4	65.000
1024	768	60	32	48.4	65.000
1024	768	70	8	56.5	75.000
1024	768	70	16	56.5	75.000
1024	768	70	32	56.5	75.000
1024	768	75	8	60.0	78.750
1024	768	75	16	60.0	78.750
1024	768	75	32	60.0	78.750
1024	768	85	8	68.7	94.500
1024	768	85	16	68.7	94.500
1024	768	85	32	68.7	94.500

1152 x 864

1152	864	75	8	67.5	108.000
1152	864	75	16	67.5	108.000
1152	864	75	32	67.5	108.000

1280 x 1024

1280	1024	60	8	64.0	108.000
1280	1024	60	16	64.0	108.000
1280	1024	60	24	64.0	108.000
1280	1024	75	8	80.0	135.000
1280	1024	75	16	80.0	135.000
1280	1024	85	8	91.1	157.500
1280	1024	85	16	91.1	157.500

1440 x 900

1440	900	60	8	59.9	106.500
1440	900	60	16	59.9	106.500
1440	900	75	8	75.0	136.750
1440	900	75	16	75.0	136.750
1440	900	85	8	84.8	157.000

Width	Height	Vertical Rate	Bits/Pixel	Horizontal Frequency (kHz)	Pixel Frequency (mHz)
1440	900	85	16	84.8	157.000

1600 x 1200

1600	1200	60	8	75.0	162.000
1600	1200	60	16	75.0	162.000
1600	1200	65	8	81.3	175.500
1600	1200	65	16	81.3	175.500
1600	1200	70	8	87.5	189.000
1600	1200	70	16	87.5	189.000
1600	1200	75	8	93.8	202.500
1600	1200	85	8	106.3	229.500

1680 x 1050

1680	1050	60	8	65.3	146.250
1680	1050	60	16	65.3	146.250
1680	1050	75	8	74.9	187.000
1680	1050	75	16	74.9	187.000
1680	1050	85	8	93.9	214.750

4.3 System Reset Control

The Intel® RMM3 utilizes the on-board Integrated BMC to initiate and indicate when system resets occur. The BIOS takes control of the system after the reset and performs system initialization. This reset signal does not reset the Intel® RMM3.

5. Network Connections and Authentication

5.1 Network Connectivity

The Intel® RMM3 requires Ethernet connectivity. Therefore, an Ethernet PHY is installed on the Intel® RMM3. This enables the Intel® RMM3 to manage these network functions:

- Dynamic Host Configuration Protocol (DHCP)
- Address Resolution Protocol (ARP)
- Internet Control Message Protocol (ICMP)
- TCP/IP

5.1.1 Supported Traffic

All Intel® RMM3 Virtual Presence features (Web GUI, Virtual Media, etc.) are supported on the dedicated 10/100 Ethernet interface. IPMI traffic to the Integrated BMC-dedicated NIC connections and via the Intel® RMM3 is only supported if the Integrated BMC-dedicated NIC and the Intel® RMM3 NIC are on separate subnets.

Glossary

Word / Acronym	Definition
ARP	Address resolution protocol
BMC	Baseboard Management Controller
CLI	Command line interface
DDC	Display Data Channel
DHCP	Dynamic Host Configuration Protocol
DVC	Dambrackas Video Compression
DVO	Dynamic Visual Output
FPGA	Field Programable Gate Array
ICMP	Internet Control Message Protocol
Intel® RMM3	Intel® Remote Management Module 3
IPMI	Intelligent Platform Management Interface
ITE	Information Technology Equipment
KVM	Keyboard, video and mouse
MAC	Media Access Controller
OOB	Out-Of-Band- No operating system interaction on Server
PBDE	Polybrominated Biphenyls Diphenyl Ethers
RMII	Reduced Media Independent Interface
RTC	Real-Time Clock
TCP/IP	Transmission Control Protocol / Internet Protocol
TPS	Technical Product Specification
UART	Universal asynchronous receiver transmitter
UDP	User Datagram Protocol