

# **MAXDATA PLATINUM 200 I**

---

## **User's Manual**



# Contents

---

<b>1 Setting up the System</b>	<b>5</b>
Safety Information .....	5
Server Position .....	5
System Access Warnings .....	6
Connecting the System .....	7
Back Panel Connectors .....	7
Powering up the System .....	8
<b>2 Server Features</b>	<b>9</b>
Connector and Header Locations .....	10
Configuration Jumpers .....	11
SSI Front Panel Connector .....	11
Hardware Requirements .....	12
Processor .....	12
Memory .....	12
Supported Memory Modules .....	12
Optional Hardware .....	12
Remote Management Module .....	12
<b>3 Hardware Installations and Upgrades</b>	<b>13</b>
Before You Begin .....	13
Tools and Supplies Needed .....	13
Removing and Installing the Bezel Assembly .....	13
Removing the Chassis Cover .....	14
Installing 5.25-inch Drive (DVD, streamer) .....	14
Installing SATA or SAS Hot Swap Drives .....	14
Installing or Replacing a Processor .....	16
Installing a Processor .....	16
Installing the Heat Sink .....	19
Removing a Processor .....	20
Installing a PCI Card .....	20
Installing and Removing Memory .....	21
Installing DIMMs .....	21
Replacing the Backup Battery .....	22
<b>4 Server Utilities</b>	<b>25</b>
Using the BIOS Setup Utility .....	25
Starting Setup .....	25
If You Cannot Access Setup .....	25
Setup Menus .....	25
Clearing the CMOS .....	27
Configuring the System for embedded Serial ATA RAID .....	28
Configuring the BIOS .....	28
Creating Intel® Matrix Storage Technology RAID set .....	28
Creating LSI Technology RAID set .....	28
Loading the RAID Drivers (Windows Server 2003) .....	29
<b>5 Rack Installation</b>	<b>31</b>
Parts List .....	31
Installation .....	32

**6 Technical Reference 35**

Power Supply Specifications .....35  
    300 W Single Power Supply Input Voltage.....35  
    300 W Single Power Supply Output Voltages.....35  
    350 W Redundant Power Supply Input Voltages .....35  
    350 W Redundant Power Supply Output Voltages .....35

**7 Regulatory and Compliance Information 37**

Product Regulatory Compliance .....37  
    Product Safety Compliance .....37  
    Product RoHS Compliance .....37  
    Product EMC Compliance .....37  
    Product Regulatory Compliance Markings .....37  
Electromagnetic Compatibility Notices .....37  
    Europe (CE Declaration of Conformity) .....37

**Figures**

1. Back Panel Connectors .....7  
2. PLATINUM 200 I Controls.....8  
3. Board Connector and Component Locations .....10  
4. Configuration Jumpers .....11  
5. SSI Front Panel Connector .....11  
6. Bezel assembly .....13  
7. Releasing Drive Carrier from Hot Swap Cage .....14  
8. Removing Plastic Retention Device .....15  
9. Securing Hard Drive to Drive Cage.....15  
10. Inserting Drive Carrier into Drive Cage.....15  
11. Opening the Processor Socket Lever.....16  
12. Opening Load Plate .....17  
13. Removing Protective Covering from the Load Plate .....17  
14. Inserting the Processor .....17  
15. Closing Load Plate and Socket Lever .....18  
16. Installing the Heat Sink.....19  
17. Installing DIMMs .....21  
18. Removing the Battery .....23

**Tables**

1. NIC LEDs.....7  
2. Feature Summary.....9  
3. Board Connectors and Components .....10  
4. Keyboard Commands.....26  
5. 300 W Power Supply Output Rating .....35  
6. 350 W Power Supply Output Rating .....35  
7. Product Certification Markings .....37

# 1 Setting up the System

## Safety Information

### Server Position

Please take note of the following criteria for creating a practical and safe workplace when setting up your computer:



### CAUTION

The system can be used anywhere the temperature is suitable for people. However, rooms with humidity over 70%, and dusty or dirty areas are not appropriate. In addition, do not expose the server to any temperatures over +30°C or under +10°C.



### CAUTION

For proper cooling and airflow, operate the system only with the chassis covers installed.



### CAUTION

Make sure that the cables connecting the server to peripheral devices are not tight.



### CAUTION

Make sure that all power and connection cables are positioned so that they are not trip hazards.



### CAUTION

When you save data to your server's hard disks or to a floppy disk, they are stored as magnetic information on the media. Make sure that they are not damaged by magnetic or electromagnetic fields.



### CAUTION

Because the electronics in your computer can be damaged by jarring, no mechanical devices should be placed on the same surface as the server. This is especially important for impact printers whose vibrations could damage the hard disk.



### CAUTION

Hazardous conditions, devices and cables: Hazardous electrical conditions may be present on power, telephone, and communication cables. Turn off the server and disconnect the power cord, telecommunications systems, networks, and modems attached to the server before opening it. Otherwise, personal injury or equipment damage can result.



### CAUTION

Electrostatic discharge (ESD) and ESD protection: ESD can damage disk drives, boards, and other parts. We recommend that you perform all procedures in chapter 3 only at an ESD workstation. If one is not available, provide some ESD protection by wearing an antistatic wrist strap attached to chassis ground - any unpainted metal surface - on your server when handling parts.



### ATTENTION

In order to fully separate the server from current, the power cord must be removed from the wall outlet.



### ATTENTION

To ensure stability, the floor stands must be turned outwards (pedestal version only).

## System Access Warnings



### CAUTION

To avoid personal injury or property damage, the following safety instructions apply whenever accessing the inside of the product:

- Turn off all peripheral devices connected to this product.
- Turn off the system by pressing the power button to off.
- Disconnect the AC power by unplugging all AC power cords from the system or wall outlet.
- Disconnect all cables and telecommunication lines that are connected to the system.
- Retain all screws or other fasteners when removing access cover(s). Upon completion of accessing inside the product, refasten access cover with original screws or fasteners.
- Do not access the inside of the power supply. There are no serviceable parts in the power supply. Return to manufacturer for servicing.
- Power down the server and disconnect all power cords before adding or replacing any non hot-plug component.
- When replacing a hot-plug power supply, unplug the power cord to the power supply being replaced before removing the power supply from the server.



### CAUTION

If the server has been running, any installed processor(s) and heat sink(s) may be hot. Unless you are adding or removing a hot-plug component, allow the system to cool before opening the covers. To avoid the possibility of coming into contact with hot component(s) during a hotplug installation, be careful when removing or installing the hot-plug component(s).



### CAUTION

To avoid injury do not contact moving fan blades. If your system is supplied with a guard over the fan, do not operate the system without the fan guard in place.

# Connecting the System

## Back Panel Connectors

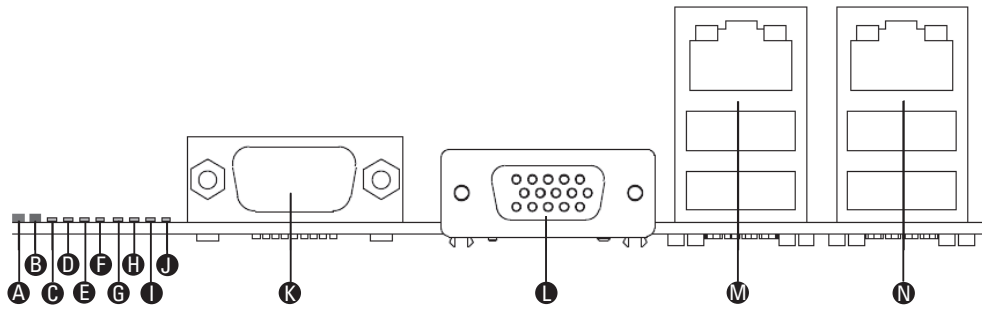

**Figure 1. Back Panel Connectors**

- |                                      |   |
|--------------------------------------|---|
| <b>A.</b> System Identification LED  | <b>H.</b> Diagnostic LED 2  |
| <b>B.</b> Status LED                 | <b>I.</b> Diagnostic LED 1  |
| <b>C.</b> Diagnostic LED 7 (MSB LED) | <b>J.</b> Diagnostic LED 0 (LSB LED)                                      |
| <b>D.</b> Diagnostic LED 6           | <b>K.</b> Serial Port A   |
| <b>E.</b> Diagnostic LED 5           | <b>L.</b> Video Port  |
| <b>F.</b> Diagnostic LED 4           | <b>M.</b> NIC 1 (top, default management port),<br>two USB ports (bottom) |
| <b>G.</b> Diagnostic LED 3           | <b>N.</b> NIC 2 (top), two USB ports (bottom)                             |

The NIC LEDs at the right and left of each NIC provide the following information.

**Table 1. NIC LEDs**

LED	LED State	Description
Left	Off	No network connection
	Solid Green	Network connection in place
	Blinking Green	Transmit/receive activity
Right	Off	10 Mbps connection (if left LED is on or blinking)
	Solid Green	100 Mbps connection
	Solid Amber	1000 Mbps connection

## Powering up the System

At the front of the case, you can find the necessary controls like power button and the HDD LEDs. Press the power button one time briefly in order to boot the server.

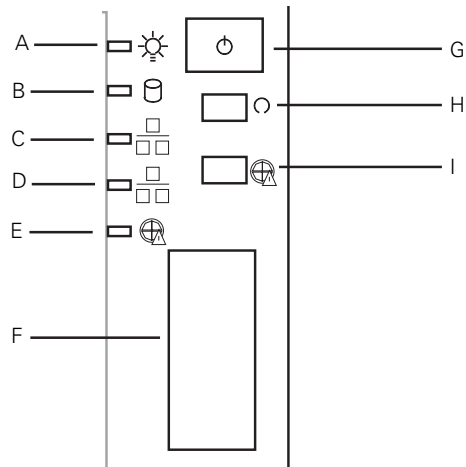

**Figure 2. PLATINUM 200 I Controls**

- |   |                                    |
|---|------------------------------------|
| <b>A.</b> Power LED                       | <b>F.</b> Front USB ports          |
| <b>B.</b> HDD LED                         | <b>G.</b> Power switch             |
| <b>C.</b> NIC2 LED                        | <b>H.</b> Reset switch             |
| <b>D.</b> NIC1 LED                        | <b>I.</b> Disable backplane alarm* |
| <b>E.</b> Critical backplane temperature* |                                    |

\* Only for PLATINUM 200 I with SAS / S-ATA backplane option. A critical temperature is signaled by the backplane via LED and at the same time by an acoustic warning. This may hint at a fan failure.

## 2 Server Features

This chapter briefly describes the main features of the server system. This chapter provides a list of server system features and diagrams showing the location of important components and connections of the server system.

Table 2 summarizes the features of the server system.

**Table 2. Feature Summary**

Feature	Description
<b>Chassis Dimensions</b>	450 mm high 195 mm wide 501 mm deep 18.0 kg max. chassis weight
<b>Processor</b>	<ul style="list-style-type: none"> <li>• Support for one Intel® Xeon® 3400 Series Processor</li> <li>• LGA 1156 socket</li> </ul>
<b>Memory</b>	<p>Two memory channels with support for 1066/1333 MHz ECC Unbuffered DDR3 DRAM (UDIMM) or ECC Registered DDR3 DRAM (RDIMM, Intel® Xeon® 3400 Series only).</p> <ul style="list-style-type: none"> <li>• Up to 2 UDIMMs or 3 RDIMMs (Intel® Xeon® 3400 Series only) per channel</li> <li>• 32 GB max with x8 ECC RDIMM (2 Gbit DRAM) and 16 GB max with x8 ECC UDIMM (1 Gbit DRAM)</li> </ul>
<b>Chipset</b>	<ul style="list-style-type: none"> <li>• Intel® 3420 Chipset Platform Controller Hub (PCH)</li> <li>• ServerEngines LLC Pilot II BMC controller (Integrated BMC)</li> </ul>
<b>Peripheral Interfaces</b>	<p><b>External connections:</b></p> <ul style="list-style-type: none"> <li>• One DB-15 graphics port</li> <li>• One DB-9 serial port A</li> <li>• Two RJ45 network ports for 10/100/1000 Mbps</li> <li>• Four USB 2.0 ports (back panel)</li> <li>• Two USB 2.0 ports (front)</li> </ul> <p><b>Internal connections:</b></p> <ul style="list-style-type: none"> <li>• One 2x5 USB connector for two USB 2.0 ports</li> <li>• One vertical type A USB connector</li> <li>• One 2x5 connector for serial port B</li> <li>• Six SATA-II ports with integrated RAID support (Matrix Storage Raid Technology, Raid 0, 1, 5, 10)</li> <li>• One port for an optional remote management module 3</li> </ul>
<b>Video</b>	On-board controller ServerEngines LLC Pilot II with integrated 2D video controller, 64 MB DDR2 memory, 8 MB of which is graphics memory
<b>LAN</b>	<ul style="list-style-type: none"> <li>• One Gigabit Ethernet 82574L controller</li> <li>• One Gigabit Ethernet 82578DM controller</li> </ul>
<b>Expansion Capabilities</b>	<ul style="list-style-type: none"> <li>• Slot 1: 5V PCI 32 bit / 33 MHz</li> <li>• Slot 2: PCI Express Gen1 x4 (x1 connection)</li> <li>• Slot 3: PCI Express Gen1 x8 (x4 connection)</li> <li>• Slot 4: PCI Express Gen2 x8 (x4 connection)</li> <li>• Slot 5: PCI Express Gen2 x8 (x8 connection)</li> <li>• Slot 6: PCI Express Gen2 x16 (x8 connection)</li> </ul>
<b>Hard Drives</b>	Support for <ul style="list-style-type: none"> <li>• two internal SATA drives</li> </ul> or <ul style="list-style-type: none"> <li>• up to four hot-swap SAS/SATA drives</li> </ul>
<b>Power supply</b>	Single or redundant 300 W / 350 W power supply
<b>Fans</b>	Support for two system fans and one processor fan
<b>System Management</b>	<p>Integrated IPMI 2.0-compliant baseboard management controller</p> <ul style="list-style-type: none"> <li>• Support for remote management module 3 ("KVM over IP")</li> <li>• Support for system management software</li> </ul>

# Connector and Header Locations

Figure 3 shows the approximate location of the major components on board.

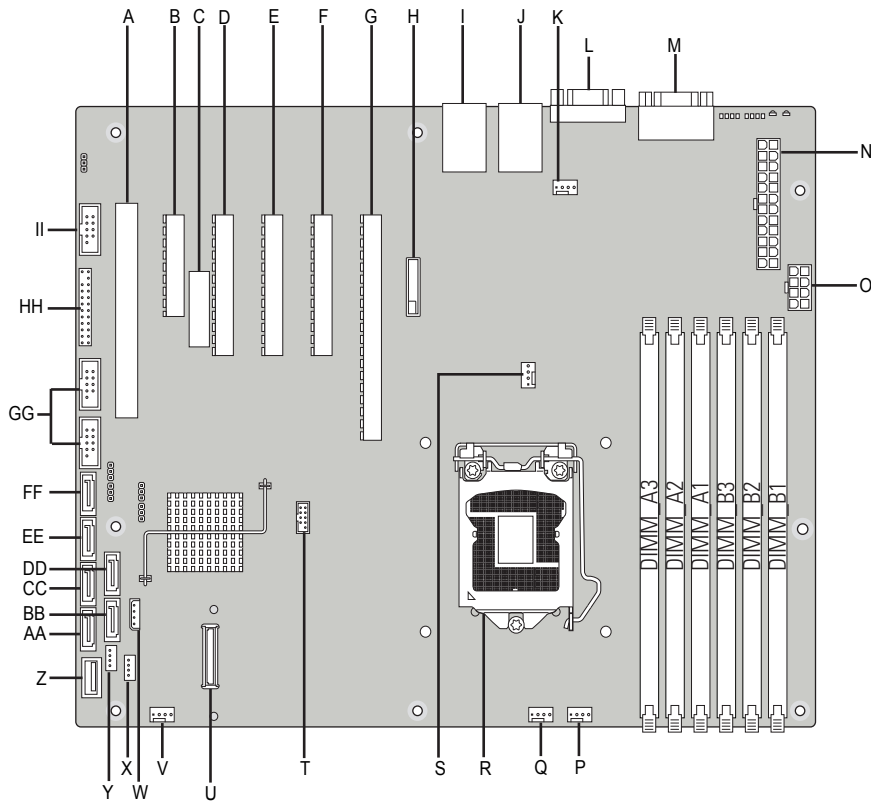

**Figure 3. Board Connector and Component Locations**

**Table 3. Board Connectors and Components**

Label	Description	Label	Description
A.	Slot 1, 32 Mbit/33 MHz PCI	S.	CPU fan connector
B.	Slot 2, PCI Express Gen1 x1 (x4 connector)	T.	USB SSD connector
C.	Intel RMM3 connector	U.	SAS module connector
D.	Slot 3, PCI Express Gen1 x4 (PCI Express Gen2 compliant)	V.	System fan 1
E.	Slot 4, PCI Express Gen2 x4 (x8 connector)	W.	IPMB
F.	Slot 5, PCI Express Gen2 x8 (x8 connector)	X.	SATA_SGPIO
G.	Slot 6, PCI Express Gen2 x8 (x16 connector)	Y.	HSBP
H.	CMOS battery	Z.	Type A USB port
I.	Ethernet and dual USB combo	AA.	SATA port 0
J.	Ethernet and dual USB combo	BB.	SATA port 3
K.	System fan 4	CC.	SATA port 1
L.	Video port	DD.	SATA port 4
M.	External serial port	EE.	SATA port 2
N.	Main power connector	FF.	SATA port 5
O.	CPU power connector	GG.	USB connectors
P.	System fan 3	HH.	Front panel connector
Q.	System fan 2	II.	Internal serial port
R.	CPU socket		

## Configuration Jumpers

Figure 4 shows the location of the configuration jumpers.

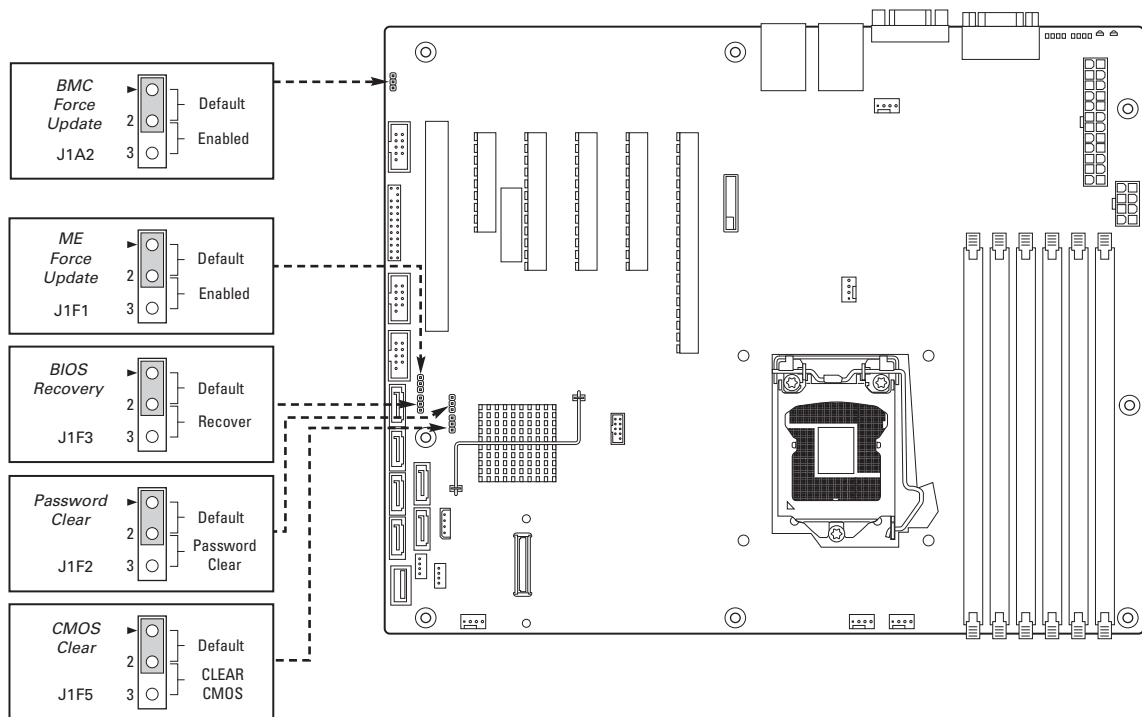

Figure 4. Configuration Jumpers

## SSI Front Panel Connector

The server board provides a 24-pin SSI front panel connector. The following figure shows the pin-out for this connector.

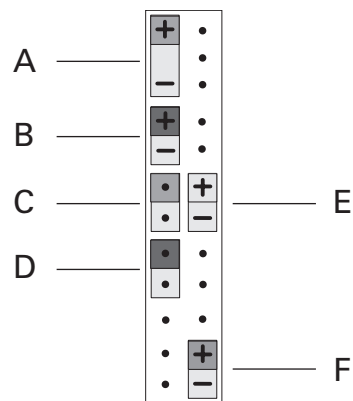

Figure 5. SSI Front Panel Connector

- |                        |                        |
|------------------------|------------------------|
| <b>A.</b> Power LED    | <b>D.</b> Reset Button |
| <b>B.</b> HDD LED      | <b>E.</b> NIC1 LED     |
| <b>C.</b> Power Button | <b>F.</b> NIC2 LED     |

## Hardware Requirements

To avoid integration difficulties and possible board damage, your system must meet the requirements outlined below.

### Processor

The mainboard supports one Intel® Xeon® 3400 series processor with up to 95 W Thermal Design Power (TDP) with 2.5 GT/s.

### Memory

The server board supports two memory channels with up to three DIMM sockets per channel. The minimal memory population is one DIMM in memory slot DIMM\_A1. Matching pairs of DIMMs accross channels is recommended (e.g. DIMM\_A2 - DIMM\_B2). Within a channel DIMM sockets with a lower number must be populated before sockets with a higher number.

### Supported Memory Modules

- 1.5 V DDR3 DIMMs, registered (RDIMMs) or unbuffered (UDIMMs)
- Mixing of RDIMMs and UDIMMs is not permitted
- The following DIMM and DRAM technologies are supported:
- RDIMMs:
  - Single, dual and quad rank
  - x8 DRAM with 2 Gbit technology
  - DDR3 1333 (only single and dual rank), DDR3 1066 and DDR3 800
- UDIMMs:
  - Single and dual rank
  - x8 DRAM with 2 Gbit technology
  - DDR3 1333, DDR3 1066 and DDR3 800

## Optional Hardware

### Remote Management Module

The Remote Management Module provides extended functions for server management.

A network card is provided specifically for remote access.

## 3 Hardware Installations and Upgrades

### Before You Begin

Before working with your server product, pay close attention to the “Safety Information” at the beginning of this manual.

System references in relation to the chassis refer to a pedestal-mounted server when viewed from the front.

### Tools and Supplies Needed

- Phillips (cross head) screwdriver (#1 bit and #2 bit)
- Needle nosed pliers
- Antistatic wrist strap and conductive foam pad (recommended)

### Removing and Installing the Bezel Assembly

To remove the bezel assembly, follow these instructions:

1. Unlock the two plastic tabs on top of the bezel assembly by pressing lightly (see Figure 6, point A).
2. Rotate the bezel assembly no more than 40 degrees forward and pull it diagonally upwards.

To install the bezel assembly, follow these instructions:

1. Place the bezel assembly with bezel hooks on the metal ridge on the lower front side of the chassis. During installation, the bezel assembly is at an opening angle of approx. 30 degrees to the top of the chassis.
2. Rotate the bezel assembly towards the chassis and push against it so that the hooks snap into place on top.

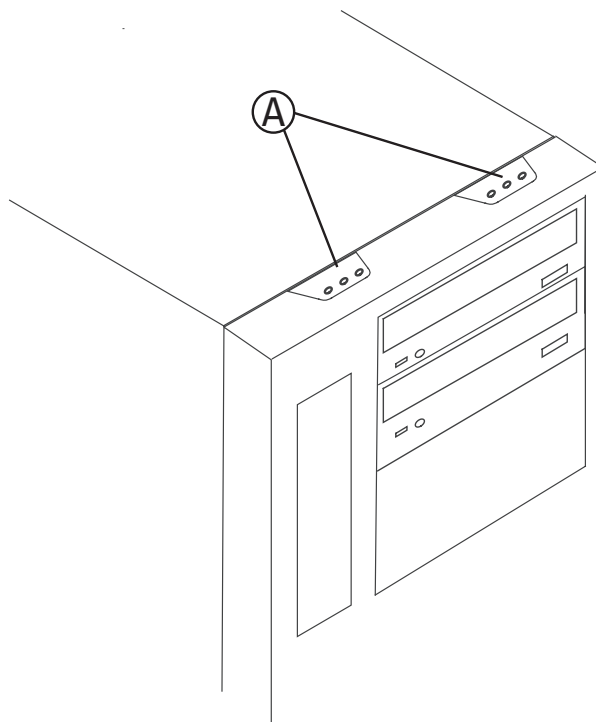

Figure 6. Bezel assembly

## Removing the Chassis Cover

1. Remove the cover.
2. Loosen the three thumbscrews that fasten the left front cover to the chassis.
3. Pull the cover outwards (approx. 1 cm) so that the guiding hooks can slide out of the chassis grooves.
4. Tilt the chassis cover upwards on its side and then take it off.

## Installing 5.25-inch Drive (DVD, streamer)

The server is supplied with a total of six mounting rails for 5.25-inch devices. Unused mounting rails can be found on the chassis beside or above the assembly areas of the drive cages.

1. Remove chassis cover.
2. Unscrew two drive rails from their storage place beside the drive cages.
3. Attach one drive rail each to the both left and right sides of the drive. The green handles should face outwards.
4. Remove the blank cover from the relevant 5.25-inch bay (chassis and bezel).
5. Finish inserting the drive into the bay until the drive rails lock into place.
6. Connect the drive to the power supply and data cable according to the manufacturer's instructions.
7. Replace the chassis cover and reconnect the bezel assembly.

To remove a 5.25-inch drive, push the green handles inwards towards the mounting rails and pull the drive and rails forwards.

## Installing SATA or SAS Hot Swap Drives

1. Press in on the green latch (letter "A") at the end of the drive carrier to disengage it from the hot swap drive cage. Pull out on the black lever (letter "B") to fully open the drive carrier. When the lever reaches a fully opened position, it will push the drive carrier out from the hot swap drive cage.

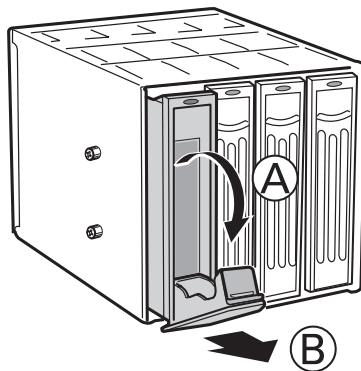

**Figure 7. Releasing Drive Carrier from Hot Swap Cage**

2. Slide the drive carrier out of the drive cage.
3. Remove the four screws that secure the plastic retention device to the drive carrier. Remove the plastic retention device.

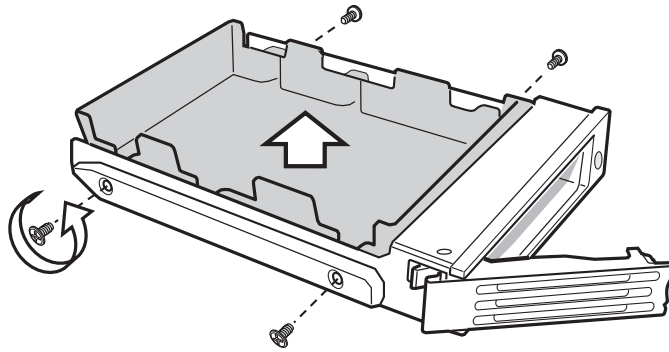

**Figure 8. Removing Plastic Retention Device**

4. Secure the hard drive to the drive carrier using the four screws that were formerly attached to the plastic retention device. Ensure that the connector end of the hard drive is facing the back of the drive carrier. The label side of the hard drive should be facing up in the drive carrier.

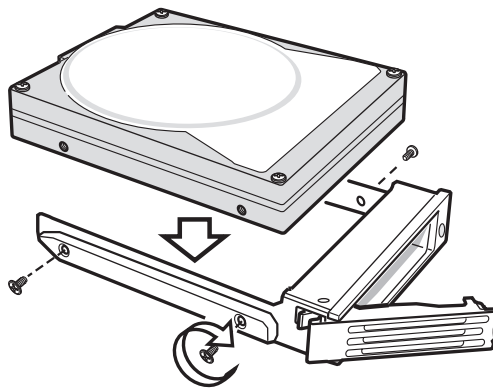

**Figure 9. Securing Hard Drive to Drive Cage**

5. With the black lever open, insert the drive carrier into the drive cage. Once inserted, rotate the black lever upwards to latch the drive carrier into position.

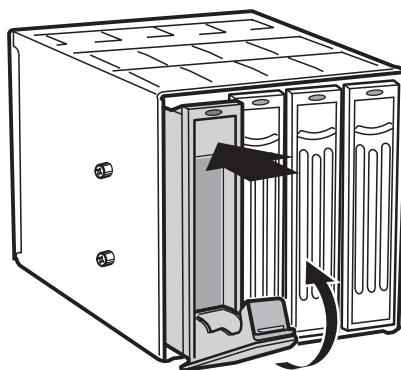

**Figure 10. Inserting Drive Carrier into Drive Cage**

# Installing or Replacing a Processor

## NOTE

Use the instructions provided below to install or replace a processor instead of using the instructions that came with the processor.

When installing a second processor, verify that the processors are identical and of the same voltage and speed. Do not mix processors of different types or frequencies.



## CAUTIONS

**Processor must be appropriate:** You may damage the server board if you install a processor that is inappropriate for your server.

**ESD and handling processors:** Reduce the risk of electrostatic discharge (ESD) damage to the processor by doing the following: (1) Touch the metal chassis before touching the processor or server board. Keep part of your body in contact with the metal chassis to dissipate the static charge while handling the processor. (2) Avoid moving around unnecessarily.

## Installing a Processor

1. Observe the safety and ESD precautions above and at the beginning of this book.
2. Turn off all peripheral devices connected to the server. Turn off the server.
3. Disconnect the AC power cord from the server.
4. Remove the server's cover.
5. Locate the processor socket (see Figure 3 on page 10).
6. Disconnect and remove any components necessary to access the processor socket.
7. Push down the lever on the processor socket. While pushing downward, push it away from the socket to release it from the hook. Open the socket lever completely. See figure 11.

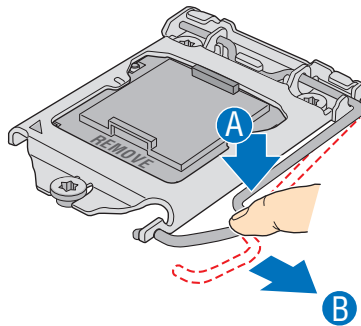

**Figure 11. Opening the Processor Socket Lever**

8. Push the rear tab with your fingertip to bring the front end of the load plate up slightly. Open the load plate completely. See figure 12.

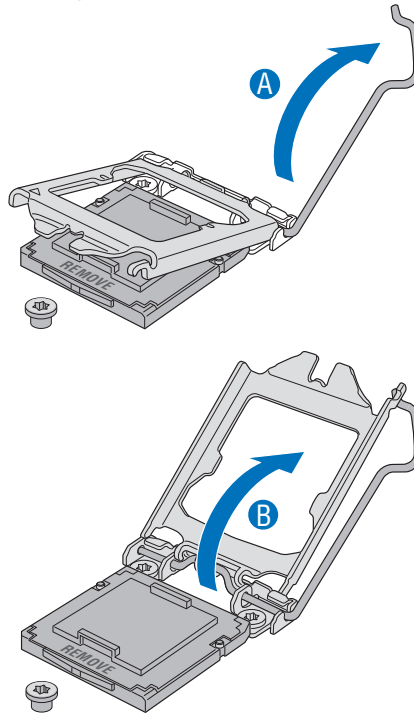

**Figure 12. Opening Load Plate**

9. If there is a protective covering on the load plate, remove it and store it for later use.

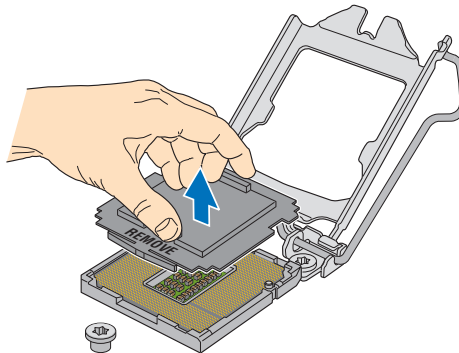

**Figure 13. Removing Protective Covering from the Load Plate**

10. Take the processor out of the box and remove the protective shipping covering.
11. Align the processor with the socket in such a way that both notches match up with the processor socket pins. Gently insert the processor into the socket.

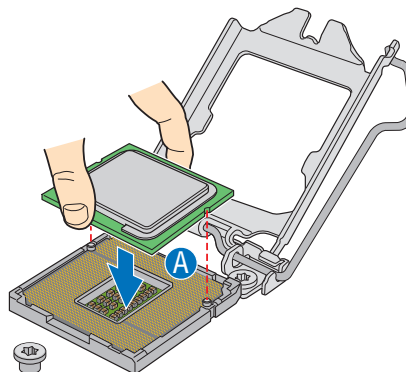

**Figure 14. Inserting the Processor**

12. Close the load plate (see letter "A"), close the socket lever, and ensure the load plate tab engages under the socket lever when fully closed (see letter "B" and "C").

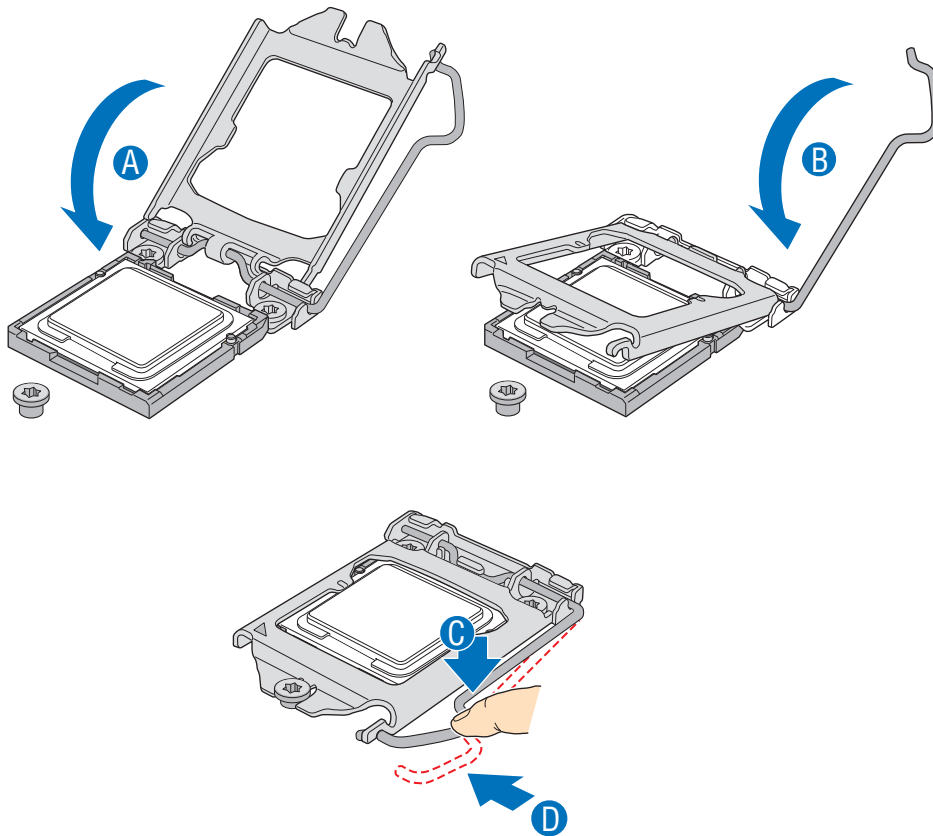

**Figure 15. Closing Load Plate and Socket Lever**

13. Attach the heat sink (see next page).

## Installing the Heat Sink

The heat sink has Thermal Interface Material (TIM) located on the bottom of it. Use caution when you unpack the heat sink so you do not damage the TIM.

1. Set the heat sink over the processor, lining up the four captive screws with the four posts surrounding the processor.
2. Loosely screw in the captive screws on the heat sink corners in a diagonal manner.  
Do not fully tighten one screw before tightening another.
3. Gradually and equally tighten each captive screw until each is firmly tightened.

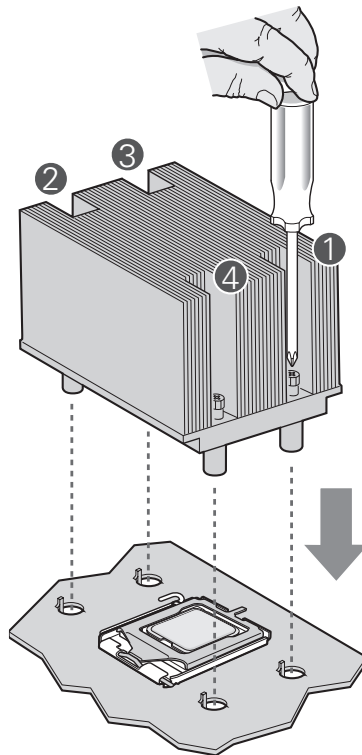

**Figure 16. Installing the Heat Sink**

4. Reinstall and reconnect any parts you removed or disconnected to reach the processor sockets.
5. Replace the server's cover and reconnect the AC power cord.

## Removing a Processor

1. Observe the safety and ESD precautions at the beginning of this book.
2. Turn off all peripheral devices connected to the server. Turn off the server.
3. Remove the AC power cord from the server.
4. Remove the server's cover.
5. Loosen the four captive screws on the corners of the heat sink.
6. Twist the heat sink slightly to break the seal between the heat sink and the processor.
7. Lift the heat sink from the processor. If it does not pull up easily, twist the heat sink again. Do not force the heat sink from the processor. Doing so could damage the processor.
8. Lift the processor lever.
9. Raise the CPU load plate.
10. Remove the processor.
11. If installing a replacement processor, see "Installing the Processor". Otherwise, install the protective socket cover over the empty processor socket and reinstall the chassis cover.

## Installing a PCI Card

Peripherals and add-in cards are not included in your system and must be purchased separately. The PCI slots support full-height add-in cards or low-profile PCI add-in cards. If a low profile card is installed in the standard full-height riser card, it must be equipped with a standard full-height PCI mounting bracket.

1. Observe the safety and ESD precautions at the beginning of this book.
2. Turn off all peripheral devices connected to the server. Turn off the server.
3. Remove power from your system by unplugging the AC power cord.
4. Remove the chassis cover.
5. Remove the screw that attaches the PCI bracket shield to the rear of the chassis to remove the shield. Retain the screw.
6. Insert the PCI card into the PCI slot.
7. Use the screw removed in step 5 to secure the PCI card to the chassis.
8. Reconnect or replace any internal components you needed to disconnect or remove.
9. Replace the server's cover. Reconnect any external components you needed to disconnect.
10. Attach the AC power cord.

## Installing and Removing Memory

The silkscreen on the board for the DIMMs displays DIMM\_A3, DIMM\_A2, DIMM\_A1, DIMM\_B3, DIMM\_B2, DIMM\_B1 starting from the center of the board. DIMM A3 is the socket closest to the processor socket. See chapter 2 – „Memory“ for a discussion of the memory requirements.

### Installing DIMMs

To install DIMMs, follow these steps:

1. Observe the safety and ESD precautions at the beginning of this book.
2. Turn off all peripheral devices connected to the server. Turn off the server.
3. Disconnect the AC power cord.
4. Remove the server's cover.
5. Locate the DIMM sockets (see figure 3).

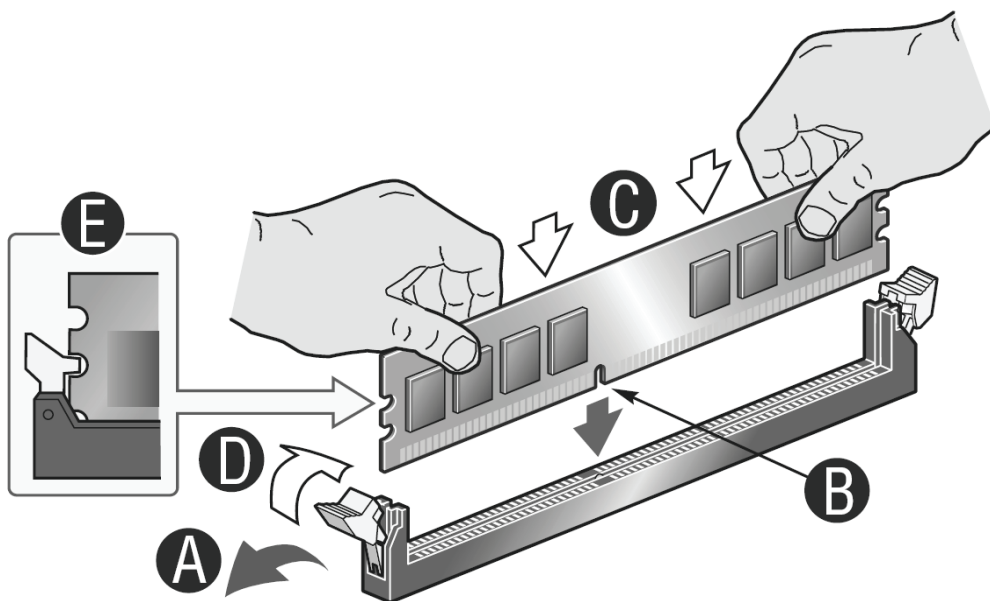

**Figure 17. Installing DIMMs**

6. Make sure the clips at either end of the DIMM socket(s) are pushed outward to the open position.
7. Holding the DIMM by the edges, remove it from its anti-static package.
8. Position the DIMM above the socket. Align the small notch in the bottom edge of the DIMM with the keys in the socket (see inset in Figure 17).
9. Insert the bottom edge of the DIMM into the socket.
10. When the DIMM is inserted, push down on the top edge of the DIMM until the retaining clips snap into place. Make sure the clips are firmly in place.
11. Reconnect or replace any internal components you needed to disconnect or remove.
12. Replace the server's cover. Reconnect any external components you needed to disconnect.
13. Attach the AC power cord.

## Replacing the Backup Battery

The lithium battery on the server board powers the RTC for up to 10 years in the absence of power. When the battery starts to weaken, it loses voltage, and the server settings stored in CMOS RAM in the RTC (for example, the date and time) may be wrong. Contact your customer service representative or dealer for a list of approved devices.



### **WARNING**

**Danger of explosion if battery is incorrectly replaced. Replace only with the same or equivalent type recommended by the equipment manufacturer. Discard used batteries according to manufacturer's instructions.**



### **WARNUNG**

**Wenn eine ungeeignete Batterie eingesetzt wird oder die Batterie falsch eingesetzt wird, besteht Explosionsgefahr. Ersetzen Sie verbrauchte Batterien nur durch Batterien gleichen oder äquivalenten Typs, der vom Hersteller empfohlen wurde. Entsorgen Sie die verbrauchte Batterie entsprechend den Anweisungen des Herstellers.**



### **AVERTISSEMENT**

**Danger d'explosion en cas de remplacement incorrect de la pile. Remplacez-la uniquement par une pile du même type ou d'un type équivalent recommandé par le fabricant. Mettez au rebut les piles usagées en vous conformant aux instructions du fabricant.**



### **OSTRZEŻENIE**

**Nieprawidłowa wymiana baterii grozi eksplozją. Wymieniać tylko na taki sam lub równoważny typ, zalecany przez producenta. Zużyte baterie utylizować zgodnie z instrukcjami producenta.**



### **ADVARSEL**

**Lithiumbatteri - Eksplosionsfare ved fejlagtig håndtering. Udskiftning må kun ske med batteri af samme fabrikat og type. Levér det brugte batteri tilbage til leverandøren.**



### **ADVARSEL**

**Lithiumbatteri - Eksplosjonsfare. Ved utskifting benyttes kun batteri som anbefalt av apparatfabrikanten. Brukt batteri returneres apparatleverandøren.**



### **WARNING**

**Explosionsfara vid felaktigt batteribyte. Använd samma batterityp eller en ekvivalent typ som rekommenderas av apparattillverkaren. Kassera använt batteri enligt fabrikantens instruktion.**



### **VAROITUS**

**Paristo voi räjähtää, jos se on virheellisesti asennettu. Vaihda paristo ainoastaan laitevalmistajan suosittellemaan tyyppiin. Hävitä käytetty paristo valmistajan ohjeiden mukaisesti.**

To replace the battery, follow these steps:

1. Observe the safety and ESD precautions in "Safety Information".
2. Turn off all peripheral devices connected to the server. Turn off the server.
3. Disconnect the AC power cord from the server.
4. Remove the server's cover and locate the battery.
5. Lift the battery retention mechanism (see Figure 18).
6. Remove the battery from its socket.

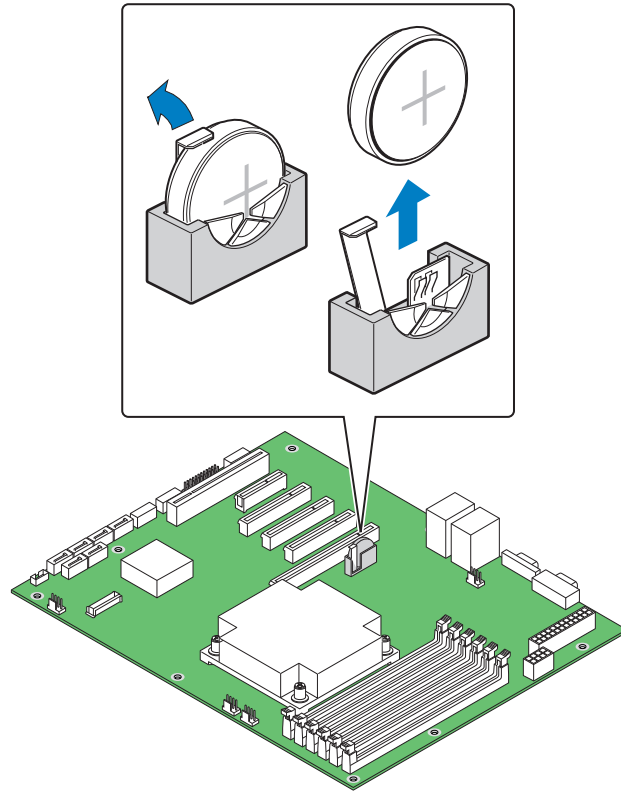

**Figure 18. Removing the Battery**

7. Dispose of the battery according to local ordinance.
8. Remove the new lithium battery from its package, and, being careful to observe the correct polarity, insert it in the battery socket.
9. Close the chassis.
10. Run Setup to restore the configuration settings to the RTC.



## 4 Server Utilities

### Using the BIOS Setup Utility

This section describes the BIOS Setup Utility options, which is used to change server configuration defaults. You can run BIOS Setup with or without an operating system being present.

#### Starting Setup

You can enter and start BIOS Setup under several conditions:

- When you turn on the server, after POST completes the memory test
- When you have moved the CMOS jumper on the server board to the “Clear CMOS” position (enabled)

In the two conditions listed above, during the Power On Self Test (POST), you will see this prompt:

```
Press <F2> to enter SETUP
```

In a third condition, when CMOS/NVRAM has been corrupted, you will see other prompts but not the <F2> prompt:

```
Warning: CMOS checksum invalid
```

```
Warning: CMOS time and date not set
```

In this condition, the BIOS will load default values for CMOS and attempt to boot.

#### If You Cannot Access Setup

If you are not able to access BIOS Setup, you might need to clear the CMOS memory. For instructions on clearing the CMOS, see “Clearing the CMOS”.

#### Setup Menus

Each BIOS Setup menu page contains a number of features. Except for those features that are provided only to display automatically configured information, each feature is associated with a value field that contains user-selectable parameters. These parameters can be changed if the user has adequate security rights. If a value cannot be changed for any reason, the feature’s value field is inaccessible.

Table 4 describes the keyboard commands you can use in the BIOS Setup menus.

**Table 4. Keyboard Commands**

Press	Description
<F1>	Help - Pressing F1 on any menu invokes the general Help window.
← →	The left and right arrow keys are used to move between the major menu pages. The keys have no effect if a sub menu or pick list is displayed.
↑	Select Item up - The up arrow is used to select the previous value in a menu item's option list, or a value field pick list. Pressing the Enter key activates the selected item.
↓	Select Item down - The down arrow is used to select the next value in a menu item's option list, or a value field pick list. Pressing the Enter key activates the selected item.
F5/-	Change Value - The minus key or the F5 function key is used to change the value of the current item to the previous value. This key scrolls through the values in the associated pick list without displaying the full list.
F6/+	Change Value - The plus key or the F6 function key is used to change the value of the current menu item to the next value. This key scrolls through the values in the associated pick list without displaying the full list. On 106-key Japanese keyboards, the plus key has a different scan code than the plus key on the other keyboard, but it has the same effect.
<Enter>	Execute Command - The Enter key is used to activate submenus when the selected feature is a sub menu, or to display a pick list if a selected feature has a value field, or to select a sub-field for multi-valued features like time and date. If a pick list is displayed, the Enter key will undo the pick list, and allow another selection in the parent menu.
<Esc>	Exit - The ESC key provides a mechanism for backing out of any field. This key will undo the pressing of the Enter key. When the ESC key is pressed while editing any field or selecting features of a menu, the parent menu is re-entered. When the ESC key is pressed in any sub menu, the parent menu is re-entered. When the ESC key is pressed in any major menu, the exit confirmation window is displayed and the user is asked whether changes can be discarded.
<F9>	Setup Defaults - Pressing F9 causes the following to appear: <pre>Setup Confirmation Load default configuration now? [Yes] [No]</pre> <p>If "Yes" is selected and the Enter key is pressed, all Setup fields are set to their default values. If "No" is selected and the Enter key is pressed, or if the ESC key is pressed, the user is returned to where they were before F9 was pressed without affecting any existing field values.</p>
<F10>	Save and Exit - Pressing F10 causes the following message to appear: <pre>Setup Confirmation Save Configuration changes and exit now? [Yes] [No]</pre> <p>If "Yes" is selected and the Enter key is pressed, all changes are saved and Setup is exited. If "No" is selected and the Enter key is pressed, or the ESC key is pressed, the user is returned to where they were before F10 was pressed without affecting any existing values.</p>

## **Clearing the CMOS**

If you are not able to access the BIOS setup screens, the CMOS Clear jumper will need to be used to reset the configuration RAM.

1. Power down the system and disconnect the AC power.
2. Open the server.
3. Move the jumper from the normal operation position, at pins 1 and 2, to the CMOS Clear position, covering pins 2 and 3.
4. Wait 5 to 10 seconds.
5. Return the CMOS Clear jumper to the Normal location, covering pins 1 and 2.
6. Close the server chassis.
7. Reconnect the AC power and power up the system.

# Configuring the System for embedded Serial ATA RAID

## Configuring the BIOS

1. Make sure you are having at least two SATA hard drives.
2. Enter system BIOS Setup by pressing the <F2> key after the Power-On-Self-Test (POST) memory tests begin.
3. Go to "Advanced" - "Mass Storage Controller Configuration"; Set "SATA Mode" to one of the following modes:
  - ENHANCED – Supports up to 6 SATA ports with IDE Native Mode (no RAID).
  - Intel ESRT – Intel® Embedded Server RAID Technology II supports RAID modes 0, 1, and 10.
  - Matrix Storage – Intel® Matrix Storage Technology supports RAID modes 0, 1, 10, and 5.
4. Save your settings by pressing <F10>.

## Creating Intel® Matrix Storage Technology RAID set

### NOTE

This RAID is supported for Windows operating systems only.

1. Upon re-boot you will see the Intel® Matrix Storage Manager Option ROM status message on the screen. Press CTRL-I to enter the RAID Option ROM user interface.
2. In the User Interface menu, select option #1; Create RAID Volume. Enter a volume name, press <enter>. The RAID Volume name must be in English alphanumeric ASCII characters.
3. Use the arrow keys to select the RAID level (0/1/5/10), press <enter>.
4. Select the drives to be used in the RAID array (only if there are more than two drives available), press <enter>.
5. Select the stripe size (only for RAID 0/5), and press <enter>.
6. Enter the size of the volume (If you select less than the maximum volume size you can create a second RAID array on the remaining portion of your volume, not recommended), and press <enter>.
7. Finally press <Y> to confirm your selections.
8. Exit the Option ROM user interface by pressing <ESC>.

## Creating LSI Technology RAID set

1. Upon re-boot you will see the Embedded RAID Option ROM status message on the screen. Press CTRL-E to enter the RAID Option ROM user interface.
2. In the Management Menu, select option #1: "Configure". Choose "Easy Configuration".
3. Mark ready drives to be used in the RAID array using the space bar and press F10 to end selection.
4. On the "Select Configurable Arrays" screen press <space> and <F10>.
5. Enter the properties of the new RAID: RAID Level (0/1/10), Size, Stripe Size. Accept the settings.
6. Exit the Easy Configuration Screen using <ESC> and save the configuration.
7. Return to the Management Menu and Initialize the new RAID.
8. Exit the Option ROM user interface by pressing <ESC>.

### **Loading the RAID Drivers (Windows Server 2003)**

1. Begin Microsoft® Windows® Setup by booting from the Microsoft® Windows® installation CD.
2. At the beginning of Microsoft® Windows® Setup, press <F6> to install a third-party SCSI or RAID driver. When prompted, insert the floppy with the RAID driver. Install the appropriate SATA RAID Controller driver, either “Intel(R) ICH9R SATA RAID Controller” for Intel® Matrix Storage Technology RAID set or “Intel Embedded Server RAID Technology” for LSI technology RAID set.
3. Finish the Microsoft® Windows® installation and install all necessary drivers.
4. Install the monitoring software included with your motherboard or after downloading it from the Internet: LSI MegaRAID Storage Manager or Intel® Matrix Storage Manager depending on the RAID technology you chose previously. This will allow for local monitoring of the RAID configuration. Additionally errors will be entered to the local system log files.







## 5 Rack Installation

The PLATINUM 200 I is available with an optional slide rail kit for rack installation. The following instructions apply to servers with this rack option only.

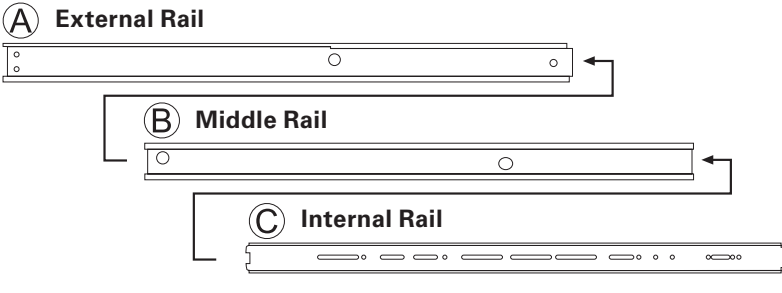
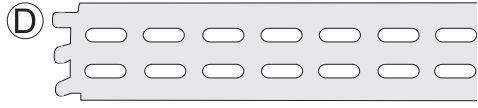
### Parts List

The following is a list of all the parts that are relevant for installation; each part is designated with a letter that is used in the installation guide.

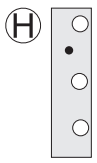
 <p><b>(A) External Rail</b>  <b>(B) Middle Rail</b>  <b>(C) Internal Rail</b></p>	<p>The middle rail (B) is slid inside the external rail (A) and the internal rail (C) in turn is inside the middle rail (B).</p>
 <p><b>(D)</b></p>	<p>End Bracket</p>
 <p><b>(E)</b></p>	<p>Round head screw, large</p>
 <p><b>(F)</b></p>	<p>Round head screw, small</p>
 <p><b>(G)</b></p>	<p>Nut</p>
 <p><b>(H)</b></p>	<p>Perforated Plate with threaded holes</p>

 **NOTE**

Countersunk screws are not required.

**Tip:** Customers with a MAXDATA rack can simplify installation of the server by taking the screws, washers, and clamping nuts from the fastening set of their cabinet.

# Installation

1. Pull the internal rail (C) out of the middle rail (B).

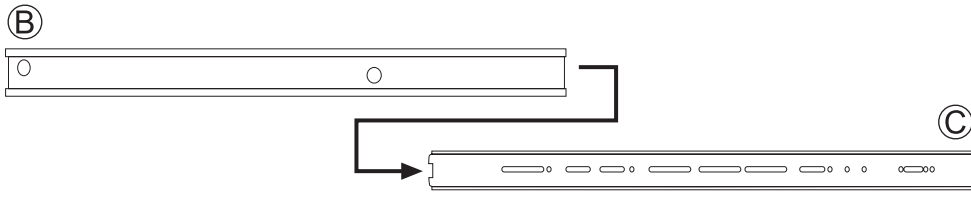

2. Leave the middle rail (B) inside the external rail (A).

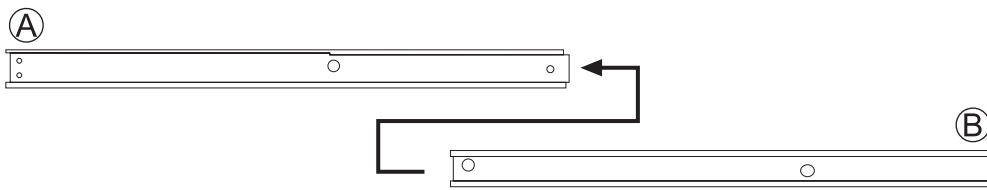

3. Measure the distance between the front and rear breadboard section of your cabinet. Attach the silver end brackets (D) to the external rail (A) with two screws (E) and two nuts (G) each. Be careful to make sure that the distance between the fastening bracket for the external rail (A) and the end bracket (D) is the same as the distance between both bread-board sections of your server cabinet.

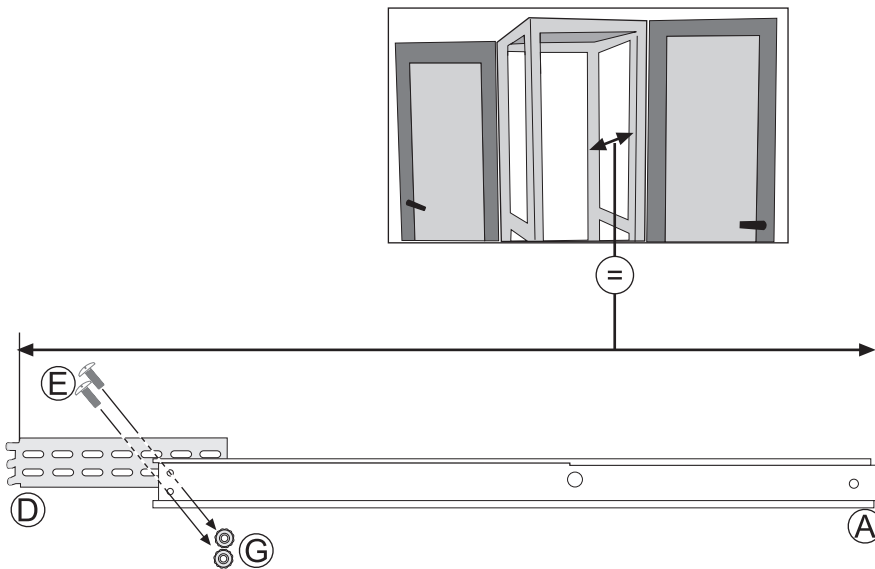

- Attach the rails in the rear of the server cabinet with the silver end brackets (D). First hold the fastening bracket up to the breadboard. Then set the perforated plate with the threaded holes (H) behind the breadboard section. Finish by inserting the screws (E) from the front through the breadboard and the fastening bracket to the perforated plates (H)

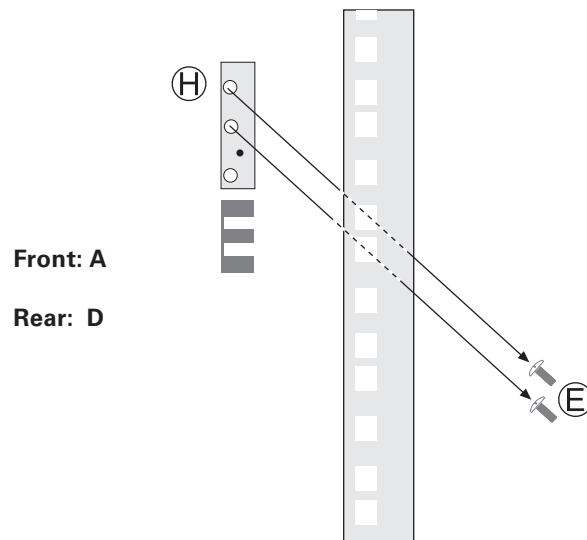

- Attach the internal rails (C) with the locking device in the rear of the server housing with the small screws (F).

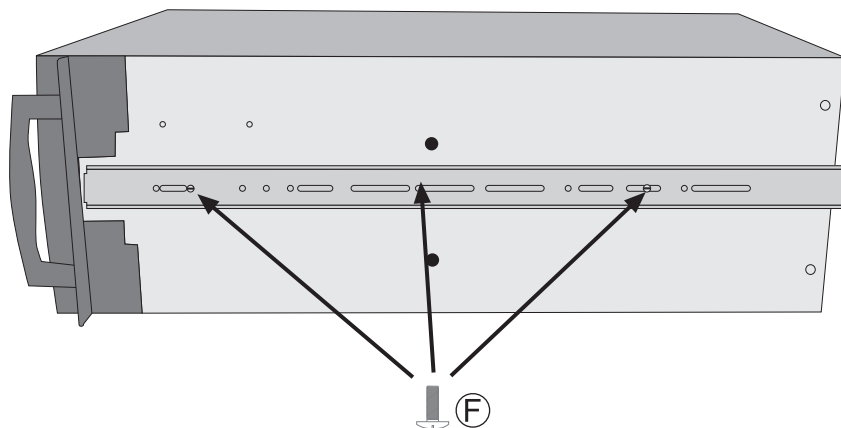

- When finished, you can slide the server into the server cabinet by pushing the inner rail (C) into the middle rail (B). To be able to slide the server completely inside, you have to push in the locking device at both sides of the rails.

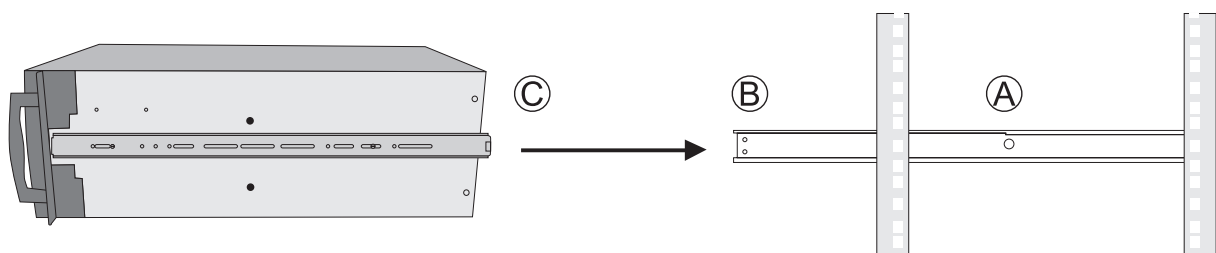



## 6 Technical Reference

### Power Supply Specifications

#### 300 W Single Power Supply Input Voltage

- 100–240 V~ at 50–60 Hz; 3.5–2 A max.

#### 300 W Single Power Supply Output Voltages

The table below lists the total wattage available for supplying power from the power subsystem for each voltage.

**Table 5. 300 W Power Supply Output Rating**

Voltage	Maximum Current
+3.3 V	20 A
+5 V	20 A
+5 V Standby	2.5 A
+12 V (2 power supply rails)	24 A (16 A for one power supply rail)
-12 V	0.5 A

#### 350 W Redundant Power Supply Input Voltages

- 100–240 V~ at 50–60 Hz; 3–6 A max.

#### 350 W Redundant Power Supply Output Voltages

The table below lists the total wattage available for supplying power from the power subsystem for each voltage.

**Table 6. 350 W Power Supply Output Rating**

Voltage	Maximum Current
+3.3 V	18 A
+5 V	25 A
+5 V Standby	3 A
+12 V	16 A
-12 V	0.5 A



# 7 Regulatory and Compliance Information

## Product Regulatory Compliance

### Product Safety Compliance

The server complies with the following safety requirements:

- EN 60950 (European Union)
- CE – Low Voltage Directive (73/23/EEC) (European Union)

### Product RoHS Compliance

Restriction of Hazardous Substances: This server system is compliant to European Directive 2002/95/EC (RoHS).

### Product EMC Compliance

The server has been tested and verified to comply with the following electromagnetic compatibility (EMC) regulations:

- EN 55022 (Class A) – Radiated & Conducted Emissions (European Union)
- EN 55024 (Immunity) (European Union)
- CE – EMC Directive (89/336/EEC) (European Union)

### Product Regulatory Compliance Markings

This product is marked with the following Product Certification Markings:

**Table 7. Product Certification Markings**

CE Mark	
---------	---

## Electromagnetic Compatibility Notices

### Europe (CE Declaration of Conformity)

This product has been tested in accordance too, and complies with the Low Voltage Directive (73/23/EEC) and EMC Directive (89/336/EEC). The product has been marked with the CE Mark to illustrate its compliance.